

Mounting plate holes dimensions and channel brackets welding

PARTS LIST

ITEM	QTY	PART NUMBER	DESCRIPTION
1	1	51-0286	Bulhead plate
2	1	51-298	Channel Bracket(with lip)
3	1	51-298	Channel Bracket(without lip)
4	1	PN19F/1	Delatchable motor
5	1	PN19F/2	Delatchable Gearbox
6	1	51-0282	Manual Override Boss
7	1	52-0284	Sprocket 08B 21 Teeth* 1/2 Simplex
8	1	5 x 40	Dowel pin
9	1	52-0433	V32 Wiper Seal
10	1	52-0441	Coupling
11	4	PN0074A	M6 x 25 Hex bolt
12	1	BS037	O-ring
13	2	M6 x 20	Hexagon Socket Cap Screw
14	2	M6 x 90	Hex bolt
15	2		6mm Flat washer
16	2	M6	Hex Nut
17	2		8mm flat washers

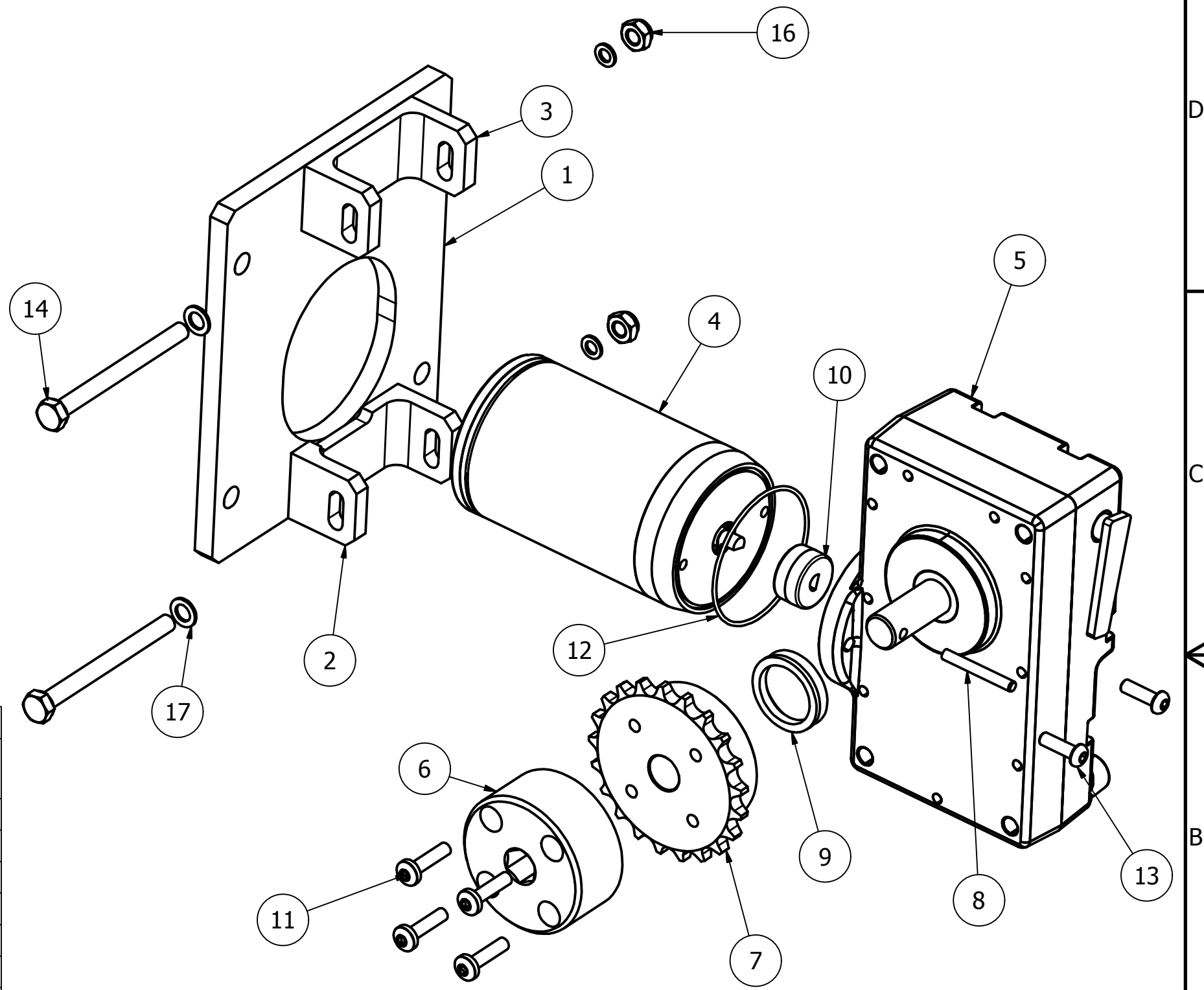

RAZOR ©

Designed by Ivan	Checked by	Approved by - date	Material	Date 11/02/2015	Sheet 1 / 1
Razor International Pty Ltd			Delatchable System assembly		
Drawing Number			Edition		